



Website



Download
(Catalogue, Manual)

〈Head office〉

5F., 14 Gobancho, Chiyoda-ku,
Tokyo, 102-0076 Japan
TEL. +81-3(5818)5134



WORCHEMI TAIWAN CO., LTD.

台灣華爾多科技股份有限公司
42955 台中市神岡區中山路915號
No.915, Zhongshan Rd., Shengang Dist.,
Taichung City 42955, Taiwan (R.O.C.)
☎ 886-4-2562-8358 📠 886-4-2562-8351
URL <https://www.worldchemical.com.tw>
E-mail worchemi@ms34.hinet.net

SUZHOU WORLD TECHNOLOGY CO., LTD

蘇州華而多科技有限公司
江蘇省蘇州市相城經濟開發區富元路61號
61, Fu Yuan Road, Xiang Cheng, Economic District.,
Su Zhou, China
☎ 86-512-6579-8212 📠 86-512-6579-8215
URL <http://www.worldchemical.com.cn>
E-mail worldchemical@wcs.szbnet.com

WORLD CHEMICAL USA, INC.

25691 Atlantic Ocean Dr. Unit B-15 Lake Forest,
CA 92630. USA.
☎ 1-949-462-0900
URL <https://www.worldchemicalusa.com>
E-mail wca@worldchemicalusa.com

■ Note

LRN series

Vertical linear seal pump SLURRY PUMP



It is ideal for transferring liquid containing slurry, because featuring a linear seal structure that magnetically seals the liquid.

Applications

- Ideal for the transfer and circulation of silicon wafer polishing slurry used in semiconductor manufacturing processes.
- Ideal for the transfer and circulation of glass polishing slurry used for LCDs and similar applications.
- Designed to eliminate issues caused by suction run-out or dry running in chemical liquid transfer applications.

Features

- The pump is equipped with a "linear seal" that seals the shaft sealing area only when the pump is stopped. This confines the air inside the pump, preventing the liquid from rising to the seal faces and eliminating the risk of leakage.
- During operation, the back vanes of the rotating impeller create a liquid balance, which prevents leakage.
- Since there is no sliding shaft seal (such as a mechanical seal) during operation, the pump is free from slurry-induced wear and heat generation caused by dry running, making it highly resistant to suction run-out and dry-running conditions.
- Since the pump does not use a mechanical seal, external cooling water is unnecessary, and no cooling water discharge.

Linear seal structure & operation

The linear seal is a shaft seal designed to prevent liquid leakage when the pump is stopped. The magnetized sealing material operates in sync with the pump's start and stop cycles to provide liquid sealing.

Because of its sealless design, which does not rely on shaft sealing by mechanical seals, there is no wear of the shaft seal caused by slurry, nor heat generation due to dry running.

In addition, when the pump is stopped, the shaft seal area is sealed by the linear seal to provide liquid sealing, making the pump suitable for installation with flooded suction piping.



Linear seal structure (YouTube)

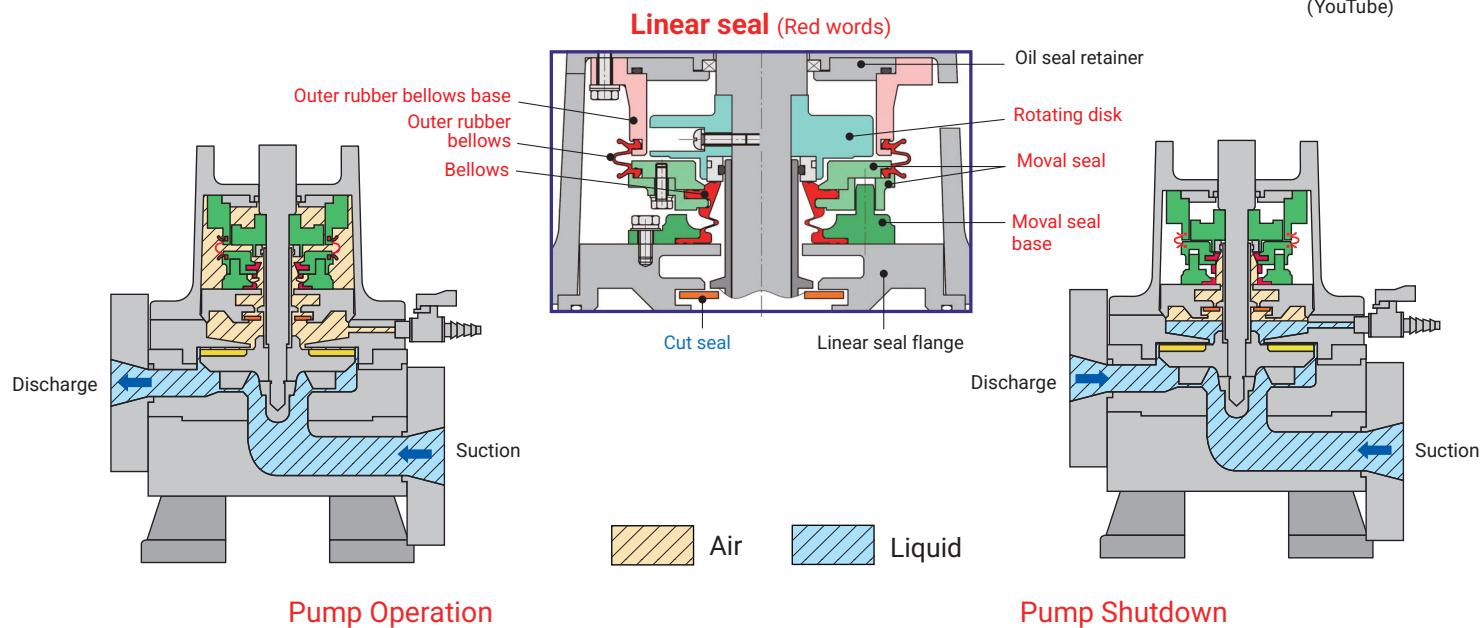

During pump operation, centrifugal force causes the magnetic poles of the magnets inside the rotating disk to change, repelling the magnets in the movable seal and opening the seal surfaces that were previously attracted and in contact. Furthermore, the action of the back vanes of the rotating impeller creates hydraulic balance, preventing the liquid from rising above the back vanes. As a result, all parts operate without contact and without sliding.

When the pump stops, the liquid level inside may rise due to backflow from the discharge side and pressure from the suction side, potentially causing leakage at the shaft seal. To prevent this movement, the cut seal closes to act as a liquid seal, but it does not completely seal. Furthermore, when the pump stops, the magnetic poles of the magnets in the rotating disk change, causing them to attract and adhere to the magnets in the movable seal. By sealing the shaft section, the air inside the pump is contained, which suppresses the rise of the internal liquid level and prevents liquid leakage. Since the shaft seal does not come into contact with the liquid, it maintains its sealing performance even with slurry-containing liquid.

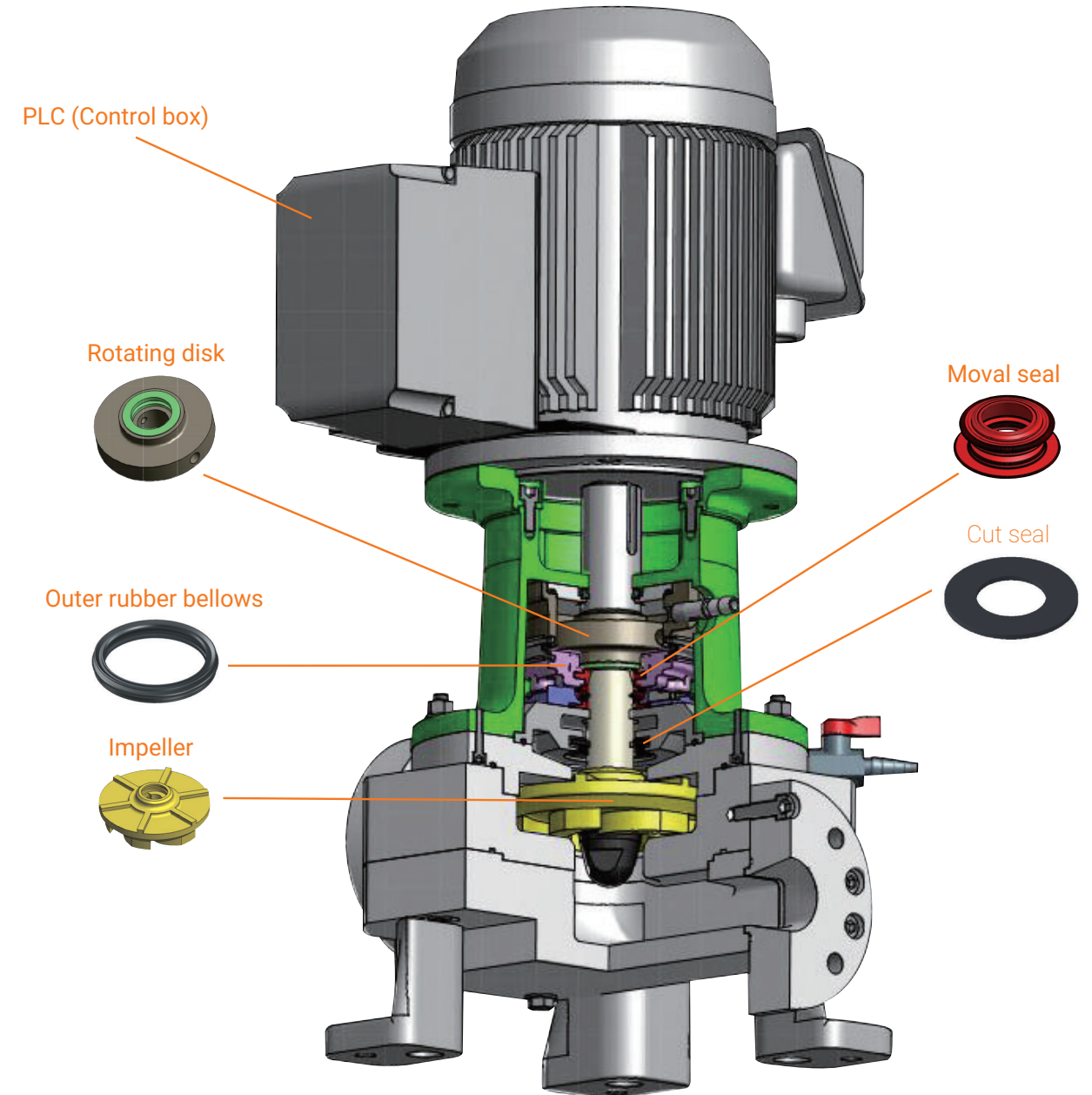

Safety Structure of the Linear Seal

① Equipped with Outer rubber bellows

In the unlikely event that the movable seal is scratched or slurry gets caught on the sealing surface, the outer rubber bellows of the seal helps minimize leakage. The outer rubber bellows is a corrugated cover that protects the movable seal and is our company's original part.

② Equipped with Proximity sensor

A proximity sensor comes standard to monitor the linear seal's operation. If the movable seal does not open and the shaft remains sealed, a pump stop signal is output. ※A signal is triggered 2 seconds after pump start if the movable seal has not opened. ※Automatic pump stop requires the customer to configure the PLC circuit. (The proximity sensor is already connected to the PLC.)

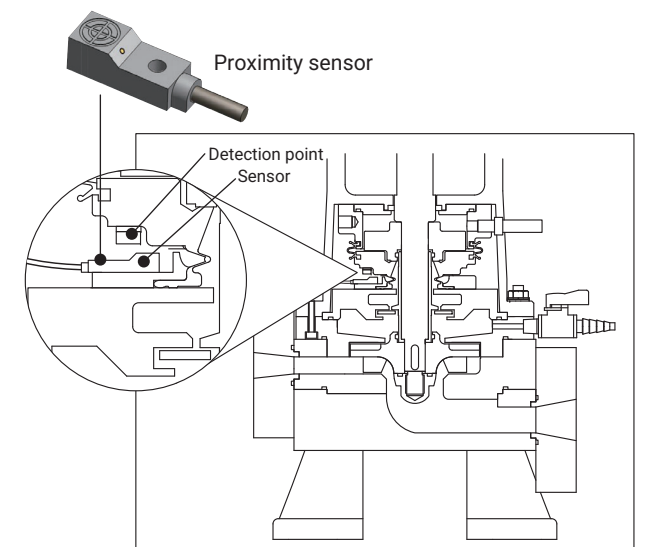

Model designation

YD-4005LRN3-PP-LD52-J

Discharge dia.

25 : 25A
40 : 40A

Model

Motor output

01 : 0.75kW
02 : 1.5kW
03 : 2.2kW
05 : 3.7kW
07 : 5.5kW

Motor type

1 : IE1 & Special motor
3 : IE3 motor

Main material

PP : PP
PE : PP / UPE

Seal material

L : Linear seal

Frequency

5 : 50Hz
6 : 60Hz

O-ring material

D : FPM
E : EPDM

Allowable S.G.

2 : 1.2

Shaft type

J : Joint shaft (as standard)

Standard specifications

Model	Bore (mm)		Standard performance THD - Capacity (m-L/min.)		Allowable S.G.	Output (kW)	Weight (kg)	Liquid temp. limit (°C)
	Suction	Discharge	50Hz	60Hz				
YD-2501LRN3	40A	25A	10 - 60	9 - 60	1.2	0.75	39.0	PP : 60°C PE : 50°C
YD-2502LRN3			13 - 100	13 - 100		1.5	45.0	
YD-4002LRN3	50A	40A	13 - 100	16 - 150		1.5	52.0	
YD-4003LRN3			15 - 150	16 - 150		2.2	56.0	
YD-4005LRN3			17 - 250	19 - 250		3.7	68.0	
YD-4007LRN3			25 - 220	25 - 280		5.5	91.0	

Performance curves

50Hz

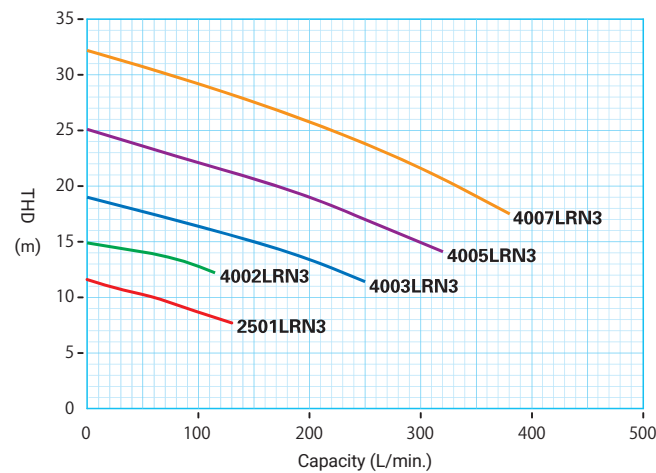

60Hz

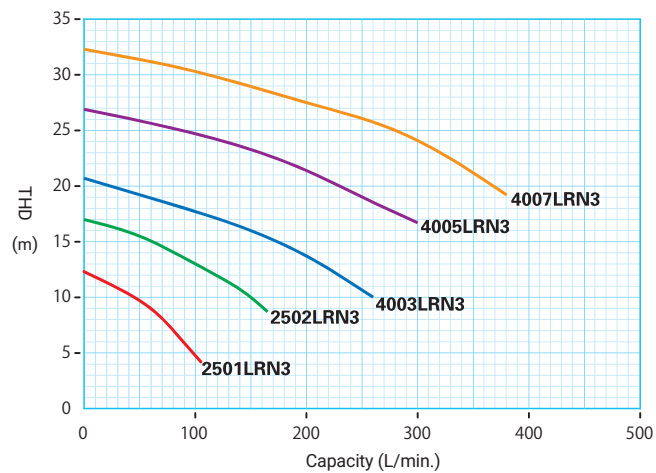

- | With crystalline slurry.
- | Operation allowed with dry suction.
- | For CMP slurry only.
- | No consumable parts.
- | Energy-saving circulation type.



Outline drawing

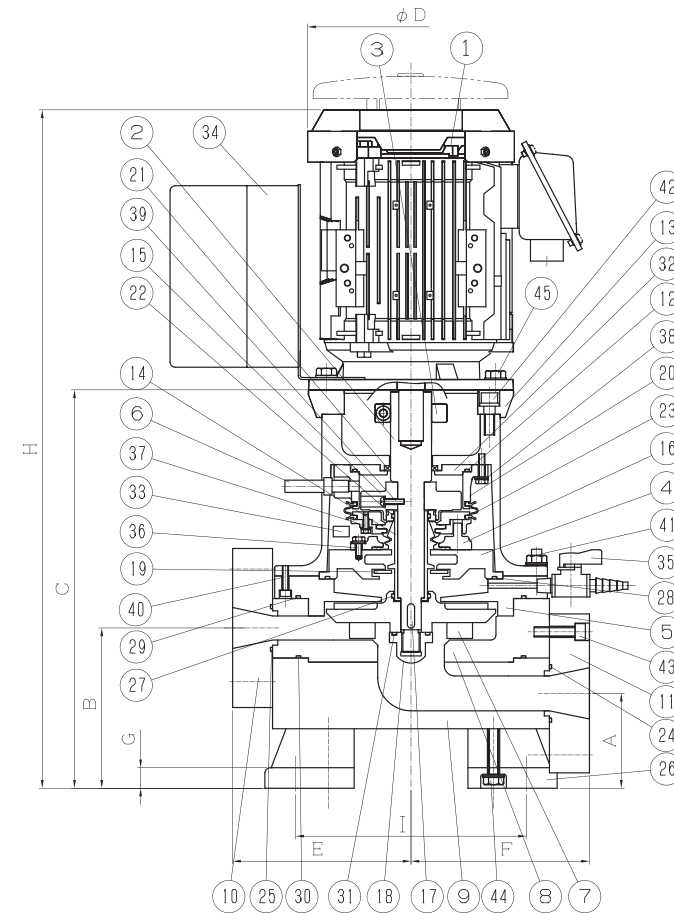

Parts list

Parts name	Material	Parts name	Material	Parts name	Material
1 Motor		17 Impeller key	Titanium	33 Proximity sensor	
2 Pump shaft	SUS304	18 Impeller nut	PP / UPE	34 Control box (Safety features 200V)	PC
3 Slit collar	S45C	19 Cut seal	FPM	35 Lab cock	EPDM / FKM
4 Linear seal flange	HT.PVC	20 Outer rubber bellows base	CFRPP	36 Phillips hex screw	SUS304
5 Back casing	PP / UPE	21 Oil seal	NBR	37 Phillips hex screw	SUS304
6 Hose joint	PP	22 O-ring for rotating disk	FPM	38 Phillips hex screw	SUS304
7 Impeller	PP / UPE	23 Outer rubber bellows	FPM	39 Phillips pan screw	SUS304
8 Casing (Discharge side)	PP	24 O-ring for suction flange	EPDM / FPM	40 Hex socket head screw	SUS304
9 Casing (Suction side)	PP	25 O-ring for discharge flange	EPDM / FPM	41 Hex socket head bolt (W,SW,N)	SUS304
10 Discharge flange	PP	26 Leg	PET	42 Hex socket head screw	SUS304
11 Suction flange	PP	27 O-ring for impeller	EPDM / FPM	43 Hex socket head screw	SUS304
12 O-ring for oil seal retainer	FPM	28 O-ring for linear seal flange	EPDM / FPM	44 Hex socket head bolt (W,SW)	SUS304
13 Connecting pipe	FC	29 O-ring for back casing	EPDM / FPM	45 Hex screw (with W)	SUS304
14 Shaft sleeve	HT.PVC	30 O-ring for casing	EPDM / FPM	46 Motor flange (Only 3.7kW)	FC200
15 Rotating disk	CFR PP + Ceramics	31 O-ring for impeller nut	EPDM / FPM		
16 Moval seal	CFR PP + FPM	32 Oil seal retainer	PP		

※③ For motors rated at 5.5 kW or higher, two slit collars are used.

Dimensions

Model	A	B	C	D	E	F	G	H	I
YD-2501LRN3	115.5	168	397	φ172	156	156	20	632.5	215
YD-2502LRN3	115.5	168	397	φ202	156	156	20	670	215
YD-4002LRN3	92.5	156	388.5	φ202	174	174	20	661.5	225
YD-4003LRN3	92.5	156	388.5	φ202	174	174	20	690.5	225
YD-4005LRN3	92.5	156	388.5	φ243	174	174	20	714.5	225
YD-4007LRN3	92.5	156	439.5	φ285	174	174	20	809	225

A highly durable, long-service-life slurry pump "LRN series" Greater energy efficiency and cost savings over time.

An **energy-efficient slurry pump** optimized for circulation and transfer in silicon wafer polishing processes. (CMP slurry liquid)

Electric motor-driven pump

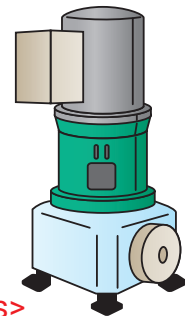

<LRN series>

Direct motor drive enables pump operation with reduced power consumption.

Energy cost

Low energy costs



High energy costs



Air-driven pump

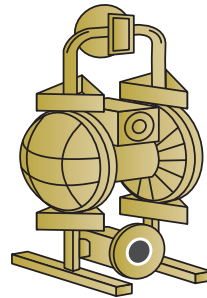

The pump is driven by compressed air produced by an electrically powered compressor, which results in high power consumption.

A **low-maintenance slurry pump** ideal for circulation and transfer in glass surface polishing processes. (Cerium oxide slurry)

Linear seal pump

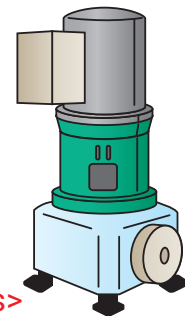

<LRN series>

The absence of sliding parts like a mechanical seal eliminates the need for external cooling water. There is also no wear on the shaft seal like a gland packing, so periodic replacement is not required.

Running cost

Low running costs



High running costs



Mechanical seal pump

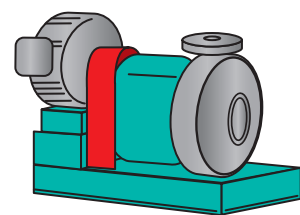

Heat generation and wear at the shaft seal require external cooling water, and the discharge of this water also adds to operating costs. Periodic replacement of consumable parts is required.

Compare it with your current pump.

- The pump fails if operated dry.
→ The absence of sliding parts makes the pump highly resistant to dry running.
- Cooling water is used to prevent heat at the shaft seal like a mechanical seal.
→ No sliding parts eliminate the need for cooling water and wastewater treatment.
- Rubber-lining pumps are used, requiring periodic replacement of consumable parts.
→ The wetted parts are made of wear-resistant resin, with no consumable parts.

Precautions for Installation and Piping

YD-LRN series

1) Precautions for installation.

- ① If a large amount of air enters the pump during operation, pumping will become impossible and may cause failure.
 - Ensure a height difference of 50 cm or more between the pump discharge outlet and the tank liquid level.
 - Avoid projections or piping with high points in the suction line that may trap air.
 - Install the suction piping with an upward slope of at least 1/100 toward the pump.
 - The suction piping should be the same size as or larger than the pump suction diameter. When different diameters are used, install a reducer and keep the top of the piping level.
- ② Install a strainer at the suction inlet of the piping to prevent the entry of debris and foreign objects. However, regularly clean the strainer to prevent clogging and minimize flow resistance.
- ③ In the cases listed below, it is recommended to install a check valve on the vertical discharge piping to prevent water hammer. Please also provide an air vent bypass pipe at the lower part. (Without an air vent pipe, self-priming may not be possible.)
 - When the discharge piping is long or when the discharge head exceeds 10 m
 - When the discharge pipe outlet is 9 m or more above the liquid level of the suction tank
 - When two or more pumps are operated in parallel under the piping conditions
- ④ To prevent deformation of the pump and liquid leakage caused by thermal expansion of the piping due to the liquid temperature, provide bends or expansion joints in the piping.
- ⑤ Since the main internal components of the pump are made of resin, handle the pump with care to avoid impact.

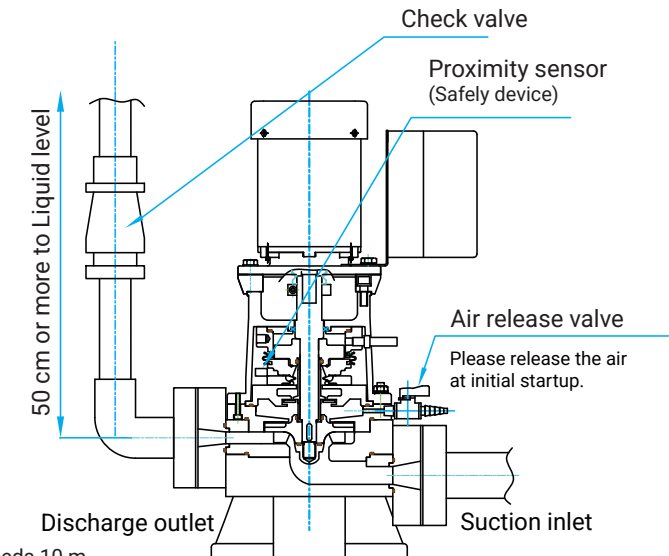

2) Overtightening of the pump flange is prohibited.

- ① Ensure that the piping flange face is parallel to the pump flange face, and do not overtighten the bolts.
- ② When a flexible joint, a SUS loose flange, or an internal gasket is used on the piping side, avoid overtightening the bolts to prevent deformation of the pump flange.

3) Do not apply any piping load to the pump.

- ① Ensure that all piping loads are fully supported by piping supports.
- ② For high temperature liquids (40°C or above), provide bends or expansion joints in the piping to prevent excessive load on the pump caused by thermal expansion.
- ③ Avoid using metal piping as much as possible, and use resin piping instead.
 - ※ In particular, for concentrated sulfuric acid and caustic soda, metal piping is often used, so please strictly follow the above 2) and 3) prohibitions.

Pump suction head

Use a flooded suction arrangement on the suction side, with a standard inlet head of 2 m. The height from the pump base mounting surface to the tank liquid level should be 2 m or less. If the pump is to be used with a suction head exceeding 2 m, please contact us. Depending on the operating conditions, higher suction heads may be acceptable.

